

LOWER VALLEY FIRE PROTECTION DISTRICT

EQUIPMENT TO BE PROTECTED

Ref: 2018 IFC, Section 312

When hazardous equipment such as liquid or gas fuel tanks, aboveground gas meters, regulators, piping, and other appurtenances are required to be protected from vehicular damage by appropriate crash posts or other approved means the following requirements shall be enforced. This would also include fire protection equipment such as fire hydrants if warranted.

Posts

Protective posts shall be at least four (4) inch diameter steel pipe and be concrete filled.

Posts shall be set not least thirty-six (36) inches deep below grade and in a concrete footing of not less than a fifteen (15) inch diameter.

Posts shall be located not more than four (4) feet, and not less than three (3) foot from tanks or equipment, and shall be so arranged so as to not interfere with maintenance or operations of the protected object.

Posts shall extend aboveground to a minimum height of 3 feet above finished grade at the protected location.

The number of posts shall be sufficient to encircle the exposed portion of the equipment to be protected. Posts shall be spaced not more than four (4) feet a part center to center.

Please refer to the figures for an example of post installation around a fire hydrant.

Concrete Barriers

Around above-ground tanks, approval *may* be given to install concrete road-barriers (jersey barriers) where barriers are spaced Not less than four (4) feet apart and four (4) feet from the tank(s) to be protected. Installation of these barriers is at the discretion of the Fire Code Official. Such barriers must conform to the requirements of the 2018 IFC, Section 312.3 with respect to resistance.

FIRE HYDRANT BOLLARD DETAIL

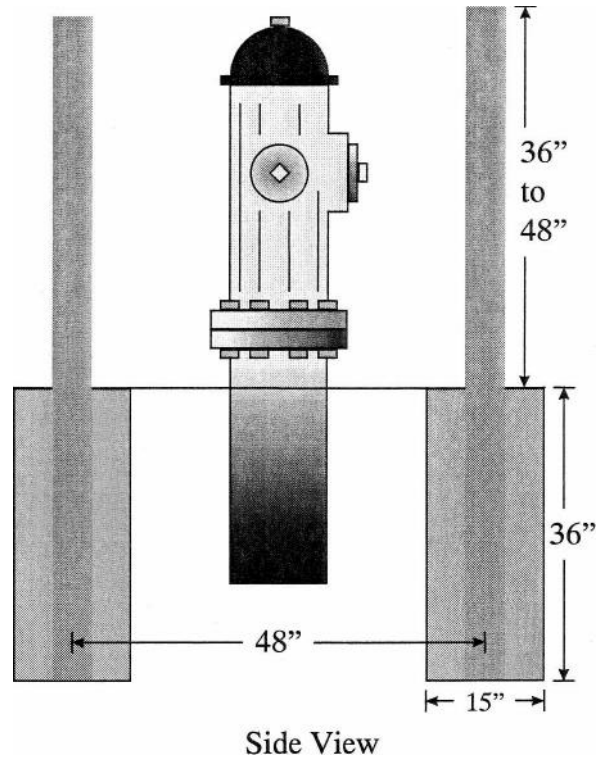

- Height of bollards (posts) not to exceed top of hydrant bonnet.
- Post height above top of asphalt or ground. MIM.3 foot, Max: 4 foot.
- Install Bollards a minimum of 36 inches deep encased in 15" (dia) of concrete.

